

Yacht Club Villas HPR
Door Hardware Standards From Schlage

Front Door Selection

Century Handleset Satin Nickel \$320.00 +7% \$22.40 = 342.40

Installation Labor \$95.00

**** Installed Totals \$437.40**

Exterior Side

Interior Side



Optional Electronic Deadbolt

The Lower Half Handleset *“Only”* As Pictured

Above *“Less”* The Deadbolt

\$260.00 +7% = \$18.20 = \$278.20

**** Installation Labor \$75.00 Installed Totals \$353.20**

Century WiFi Enabled Electronic Deadbolt - Optional



\$440.00 +7% \$30.80 = \$470.80

Installation Labor \$85.00

**** Installed Totals \$555.80**

(Apple Device Capable Shown Is An Additional \$37.45)

Rear Door Levers/ Knobs / Deadbolt Selections

Standard Deadbolt - *Available For Use On Rear Door Only*



Deadbolt	\$65.00
Tax	\$ 4.55
Installation Labor	\$ 45.00
** Totals	\$114.55

Rear Door Lever Selections



"OR"



Passage Lever \$ 60.00

Tax 7%	\$ 4.20
Installation Labor	\$ 45.00
** Totals	\$109.20

Entry Levers \$110.00

Tax 7%	\$ 7.70
Installation Labor	\$ 45.00
** Totals	\$162.70

Standard Door Viewer With Privacy Flap

\$20.00 +7% \$1.40 = 21.40
Installation Labor \$45.00 Or If No Prep For Peep \$75.00
** Installed Totals \$66.40 Or \$96.40



Door Knockers

THIS IS THE ONLY OPTION AVAILABLE ON THE 4.25" SCREW CENTERS

Door Knockers - 4.25" Screw Centers - Satin Nickel
Urn Style - \$50.00 Each + 7% - \$3.50 = 53.50
Installation Labor \$50.00 Or If No Prep For Kocker \$75.00
** Installed Totals \$103.50 Or \$128.50

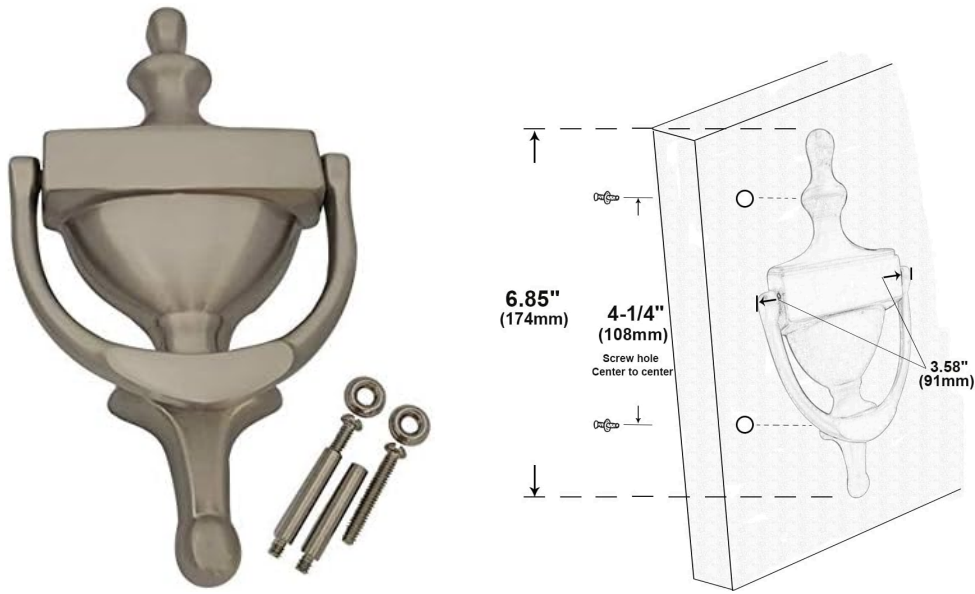

** The prices indicated are presuming that all required holes are prepared correctly and no additional door prep would be required to install the hardware in question. Any additional work that would be required to complete the installation will be charged accordingly.

***** Our Normal Trip Charge Rate Is \$75.00 Per Unit.
We Are Reducing That Rate To A \$40.00 Trip Charge Per Unit
For The Duration Of This Project.**

**The Project Should Be Completed Within 90 Days From The Date Of Acceptance.
Those who Procrastinate, Will Be Charged The Full Service Call Rate**

All Lock hardware is by Schlage. The door viewer is by Emtek, The door knocker is a Taiwan import. All hardware is to be in a Satin Nickel finish.

The front doors are to have the “Century” design handleset and deadbolt on the exterior, giving a modern look to the building and having round *rosettes on the inside.

**The rosette is the portion of the lock that is tightened to the door.*

The reasoning for the round rosette is so that over time with normal usage the rosette does not appear to be out of square on the door as would happen and show with a century style rosette, resulting in an undesirable look.

Optionally, there is a WiFi enabled lock available for use on the front and or rear doors. It will be of a Century design and is also available with Apple Device capabilities as well for an additional charge.

The door viewer with flap is for those that currently have a door viewer and for those that would like to have one installed.

The door knocker is an urn style and is the only knocker that I have been able to locate that is compatible with the existing knockers installed on most units.

The rear doors would have a basic entrance (locking) or passage (non-locking) lever with the round rosette inside and outside along with either a mechanical or electronic deadbolt.

It would be the responsibility of each homeowner to pay Areawide Decorative hardware & Locksmith Inc. directly for the work performed on an individual unit.

The costs for an individual villa may be estimated by making your preferred selections and then adding the totals of the installed costs associated with each product chosen.

We will be able to provide a quote to you prior to performing any work on your villa. Please fill out the questionnaire below.

Yacht Club Villas Door Hardware - Questionnaire / Order Form

Owner Name _____

Yacht Club Villas Unit Number _____

Contact Phone Number _____

Email Address For Formal Quote For Your Particular Unit

Front Door Options:

Century Handleset With Mechanical Deadbolt Yes ____ No ____

Century Handleset With WiFi Enabled Deadbolt Yes ____ No ____

Century Handleset With WiFi - Apple Deadbolt Yes ____ No ____

Door Peep Needed / Wanted? Yes ____ No ____

Is the door Prepped For A Peep? Yes ____ No ____

Door Knocker Needed / Wanted? Yes ____ No ____

Is The Door Prepped For A Knocker? Yes ____ No ____

Rear Door Options:

Non- Locking Passage Lever Wanted? Yes ____ No ____

Locking Entrance Lever Wanted? Yes ____ No ____

Mechanical Deadbolt Wanted? Yes ____ No ____

WiFi Deadbolt Wanted? Yes ____ No ____

Apple Enabled WiFi Deadbolt Wanted? Yes ____ No ____

Please Send This Hardware Needs Questionnaire To:

areawidelocksmith.jay@gmail.com **Our Office Number Is 843-686-4007**

We will get back to you soon with a proper quote for your particular villa. Please bear in mind that we may need to actually enter your villa to inspect the doors to accurately present a proper quote. **A key or code should be made available either from you or from the IMC Resort Services office.**

If we need to get a key or code from the IMC Resort Services office, please sign below as an authorization to receive your villa keys from them as well as your authorization for Areawide Decorative Hardware & Locksmith enter your villa.

Signed _____ Dated _____